

Modular High Performance Collector

Models MHP-1, -2, -3

Mist collector designed to filter and reclaim mist generated from machines using oil-base, synthetic, semi-synthetic, or water-soluble coolants.



MHP-3



MHP-1

- Three-stage filtration for high filtration efficiency and optimum filter life.
- Handles oil mist and smoke, with small amounts of particulate, in applications from 1000-4000 cfm.
- Standard Minihelic®* gauges indicate when filter maintenance is required.
- Hinged access doors make filter changeout simple and easy.
- Pleated high-loft fiberglass media continuously drains even under heavy loads and is washable.
- Recirculation of clean air reduces need for costly make-up air.
- Powder coated finish is durable and chemical resistant.
- Optional prefilters available with high efficiency for improved filter life in high-loading and heavier particulate applications.

Modular High Performance Collector

Dimensions & Specifications

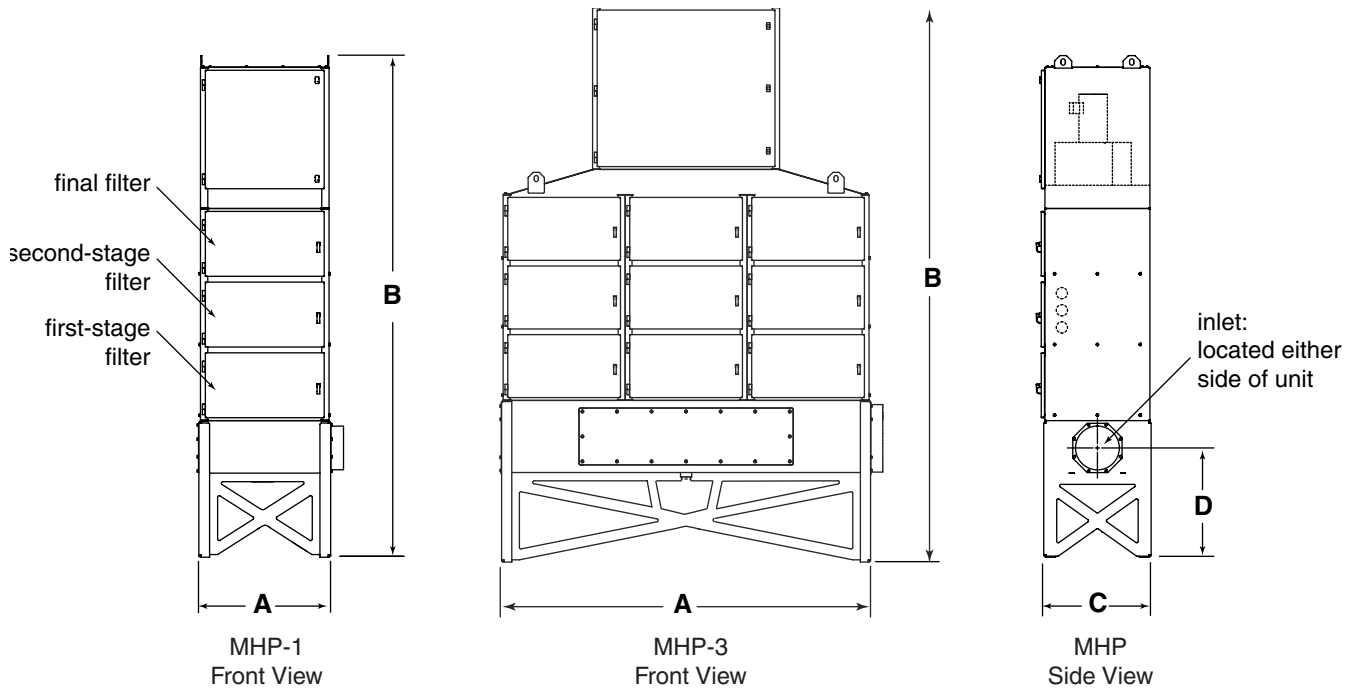

Model	Nominal Airflow** (cfm)	Motor (hp)	Inlet Collar (in)	Dimensions (in)				Shipping Weight (lbs)
				A	B	C	D	
MHP-1	1300	3	10	30.8	117.1	25.1	25.5	790
MHP-2	2600	5	14	60.8	131.4	25.1	28.8	1325
MHP-3	3900	7.5	16	90.8	133.4	25.1	29.8	1800

Equipment Options

- Prefilters
 - Impinger
 - 4" Multi-Vee
 - First-stage high efficiency filter
24" x 24" x 4"
- 2" P-Trap
- 2" P-Trap with Y-Strainer assembly
- HEPA or 95% DOP final filter,
24" x 24" x 11.5"
- Remote-mount Magnehelic®* gauge
- Sprinkler head

* Minihelic and Magnehelic are registered trademarks of Dwyer Instruments, Inc.

** Based on clean filters



Donaldson Company, Inc.
Industrial Air Filtration
P.O. Box 1299
Minneapolis, MN 55440
Tel 800-365-1331(USA)
Tel 800-343-3639 (within Mexico)
dustmktg@mail.donaldson.com
www.donaldson.com

Significantly improve the performance of your collector with genuine Donaldson Torit replacement filters and parts.

Browse our catalog at www.donaldson.com

Information in this document is subject to change without notice.

© 2003 Donaldson Co., Inc.
Printed in U.S.A. on recycled paper

Data Sheet Modular High Performance (08/07)



Visit us online at DustCollectionPros.com

Our Business is Improving Your Workplace Air Quality.



Since 1995, Environmental Solutions has been helping businesses, like yours, improve their workplace air quality. As an authorized service center for Donaldson Torit, we offer you a one-stop shop for equipment, service, engineering and installation of the industry's leading air pollution control systems.

Whether your company requires the removal of oil mist, welding fumes, machining or wood-working dust, graphite, or correction of any other type of air quality problem; we can expertly engineer and install a quality Donaldson Torit solution to meet your unique needs. No system is too big or too small.

TOLL FREE 1-866-438-7891

 **Environmental**
Solutions

12427 Fire Island Drive
Loves Park, IL 61111
Phone: (847) 370-9304

Environmental Solutions is also your source for discount pricing on genuine Donaldson Torit Replacement Filters!

DONALDSON TORIT SALES | INSTALLATION | REPLACEMENT FILTERS